

PICK-UP TRAILER

Electric assistance trailer with Kaptor© K-Ryole technology.
Open box, removable sides and integrated sheaths.



134 rue d'aubervilliers – 75019 PARIS
+ 33(0)9 72 14 48 94



OPERATIONS



1. Control equipment

Machine management keypad, handle and bike attachment, Kaptor sensor

2. Anti-theft

Motor, battery rack locks (RFID system)

3. Propulsion

2 wheel drive (3000 W)

4. Braking system

Electric braking, Hydraulic parking brake

5. Suspension

Shock absorber spring assembly, Silent block

6. Headlights

Position, brakes and reverse lights

DIMENSIONS

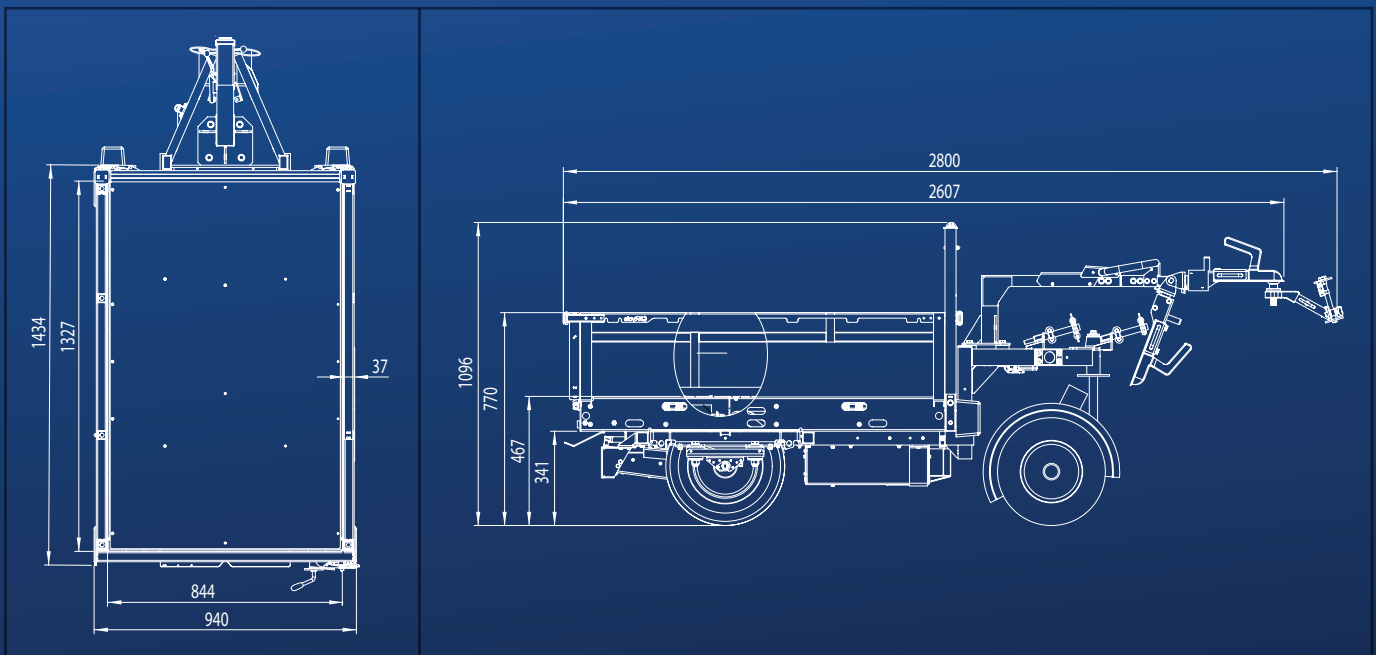

MAIN FEATURES

Bodywork		Pick-Up
Use		Hand / Bicycle
Warranty		2 years

TECHNICAL FEATURES

Materials	6060 T6 tubular aluminium frame / Self-supporting tubular aluminium structure		
Electric motor	2 DC wheel motors		
Power	2 x 1500 W		
Empty vehicle weight	150 kg		
Length / Width / Height (drawbar folded)	2199 x 940 x 1096 mm		
Wheels	Front	Dimensions	8 inch rim
		Tyre	8"x3" Tubeless
	Rear	Type	Wheel hub motor rim
		Dimensions	10 inches
		Tyre	Reinforced tyre 100/90 tubeless (100/90 R10 6J TL RF)
Technology	International patent	Kaptor K-Ryole : FR3048223BI	
	Force Cancellation Algorithm Calculation Period	Motors speed refresh rate 100 times per second	

PERFORMANCE

Drop sides	3 folding and removable drop sides	
Maximum speed	Hand Mode	7 km/h
	Bicycle mode	25 km/h
Module length / width / height	1327 x 844 x 303 mm	
Max payload	Jusqu'à 350 kg	
Slope	4%	Payload 350 kg
	11%	Payload 195 kg
	15%	Payload 115 kg
Battery	Battery Type	NMC Lithium batteries (rackable)
	Capacity	1.6kWh
	Range / unit	+/- 30-40 km
	Charging time	4 h on 220 V mains
	Operating temperature	-10 – 45° C

SAFETY

Brakes	Braking system	Electric braking
	Parking brake	Hydraulic brake
Braking distance (bike mode)	Payload 215 kg	15 km/h Dry pavement: 3.7 m / Wet pavement: 4.2 m
		25 km/h Dry pavement: 10 m / Wet pavement: 12 m
Suspension	Front	Shock absorber spring assembly (Stroke: 80 mm)
	Rear	Silent block
Anti-theft device	Parking mode	Motor lock (RFID system)
	Battery rack	Mechanical code locks
Locking	Drop sides	Latches
	Sheaths	Swivelling index pins
Cruise control / speed limiter	25 km/h	
Headlights	Position, brakes and reverse lights	
Body strength	Sheet thickness	1 mm
	Impact protection	2 front rubber deflectors
On'board Intelligence	Automatic speed limiter	Virages / Descentes
	Accidental uncoupling / Impacts	Turns / descents
	Diagnosis and intelligent correction of anomalies	Hardware / Motors
	"Dead man" safety system (drawbar release detection)	Hand Mode

EQUIPMENT

Trailer keypad interface	Hand and bike mode / Power on and off / Trailer calibration / Anti-theft mode / Maintenance indicators / Charge indicator	
Badge	Master badge (activation of user badges) / User badge (RFID function)	
Handle	Manual vehicle manoeuvring	
Bicycle hitch	Trailer	Caravan hitch on drawbar
	Bicycle	Tow ball with quick release seat post
Battery	Charging indicator	