

LIFTGATE TRAILER

Electric assistance trailer with Kaptor® K-Ryole technology.
Platform with liftgate and electric winch for assisted loading and unloading pallets.



134 rue d'aubervilliers – 75019 PARIS
+33 (0)9 72 14 94 33



OPERATION



1. Control equipment

Machine management keypad, handle and bike attachment, Kaptor sensor

2. Anti-theft

Motor and battery rack locks (RFID system)

3. Propulsion

2 wheel drive (3000 W)

4. Braking system

Electric braking, Hydraulic parking brake

5. Suspension

Shock absorber spring assembly, Silent block

6. Headlights

Position, brakes and reverse lights

7. Loading system

Electric winch with remote control, pallet attachment

DIMENSIONS

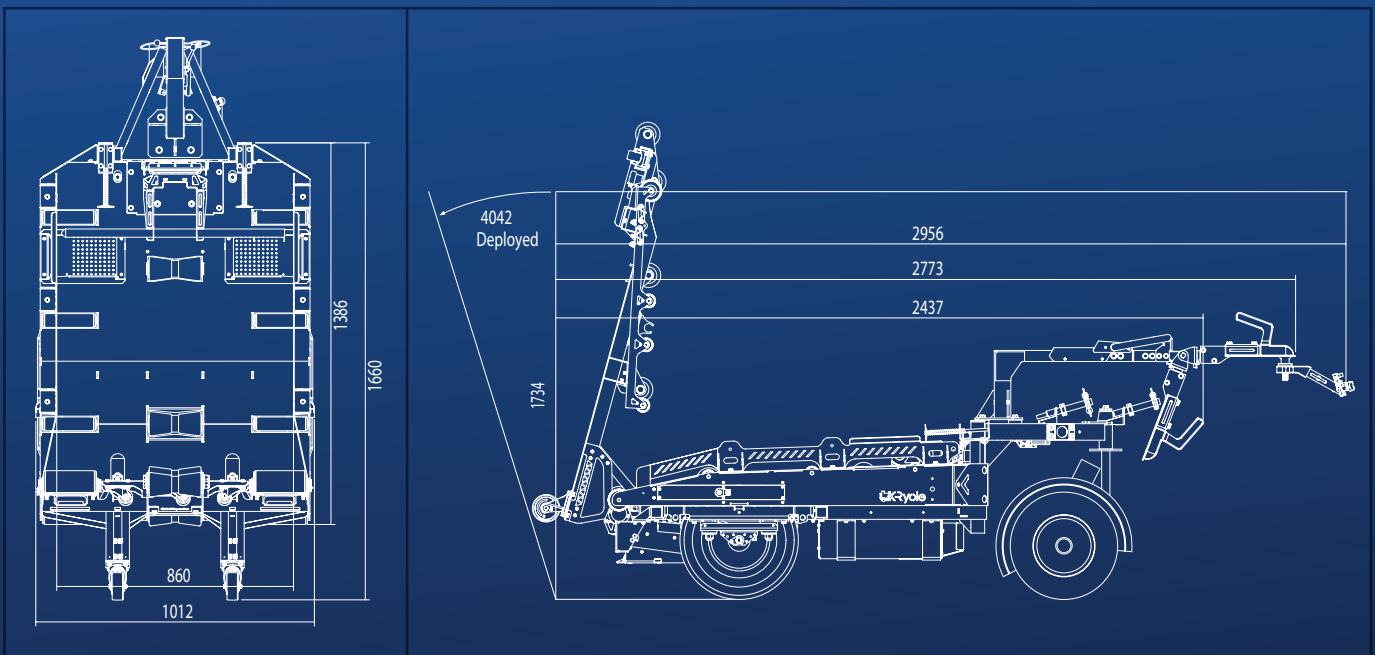

MAIN FEATURES

Bodywork	Flatbed with liftgate
Use	Hand / Bicycle
Warranty	2 years

TECHNICAL FEATURES

Materials	6060 T6 tubular aluminium frame / Aluminium structure		
Electric motor	2 DC wheel motors		
Power	2 x 1500 W		
Empty vehicle weight	197.5 kg		
Length / Width / Height	Drawbar folded and liftgate closed	2437 x 1012 x 1734 mm	
	Drawbar folded and liftgate open	3525 x 1012 x 1734 mm	
Wheels	Front	Dimensions	8 inch rim
		Tyre	8"x3" Tubeless
	Rear	Typologie	Wheel hub motor rim
		Dimensions	10 inches
Technology	International patent	Kaptor K-Ryole : FR3048223BI	
	Force Cancellation Algorithm Calculation Period	Motors speed refresh rate 100 times per second	

PERFORMANCE

Liftgate	Manual liftgate (inclination when loaded 12%)	
Winch	Electric winch / Synthetic rope	
Maximum speed	Hand Mode	7 km/h
	Bicycle mode	25 km/h
Max payload	Weight	Up to 350 kg
	Pallet (maximum dimensions)	EPAL (800 x 1200 mm)
Slope	4%	Payload 320 kg
	11%	Payload 150 kg
	15%	Payload 70 kg
Battery	Battery Type	NMC Lithium batteries (rackable)
	Capacity	1.6kWh
	Range / unit	+/- 30-40 km
	Charging time	4 h on 220 V mains
	Operating temperature	-10 – 45° C

SAFETY

Brakes	Braking system		Electric braking
	Parking brake		Hydraulic brake
Braking distance (bike mode)	Payload 170 kg	15 km/h	Dry pavement: 3.7 m / Wet pavement: 4.2 m
		25 km/h	Dry pavement: 10 m / Wet pavement: 12 m
Suspension	Front	Shock absorber spring assembly (Stroke: 80 mm)	
	Rear	Silent block	
Anti-theft device	Parking mode	Motor lock (RFID system)	
	Battery rack	Mechanical code lock	
Cruise control / speed limiter			25 km/h
Headlights			Position, brakes and reverse lights
Body strength	Impact protection		2 front deflectors
On board Intelligence	Automatic speed limiter		Turns / descents
	Automatic safety system		Accidental uncoupling / Impacts
	Diagnosis and intelligent correction of anomalies		Hardware / Motors
	"Dead man" safety system (drawbar release detection)		Hand Mode

EQUIPMENT

Trailer keypad interface	Hand and bike mode / Switching on and off / Trailer calibration / Anti-theft mode / Maintenance indicators / Charging indicator	
Winch remote control	Radio control and wired control	
Badge	Master badge (activation of user badges) / User badge (RFID function)	
Handle	Manual vehicle manoeuvring	
Bicycle hitch	Trailer	Caravan hitch on drawbar
	Bicycle	Tow ball with quick release seat post
Battery	Charging indicator	