

UTILITY TRAILER

Electric assistance trailer with Kaptor© K-Ryole technology. Convertible box, secure side door and double rear door.



134 rue d'aubervilliers – 75019 PARIS
 ☎ + 33 (0)9 72 14 48 94



OPERATION



1 Control equipment

Machine management keypad, bicycle handle and attachment, Kaptor sensor

2 Anti-theft

Motor (RFID system), rear door and battery rack locks

3 Propulsion

2 wheel drive
 (3000W power)

4 Braking system

Electric braking, hydraulic parking brake

5 Suspension

Combined shock absorber, spring and silent block

6 Headlights

Side, brake and reverse lights

DIMENSIONS (mm)

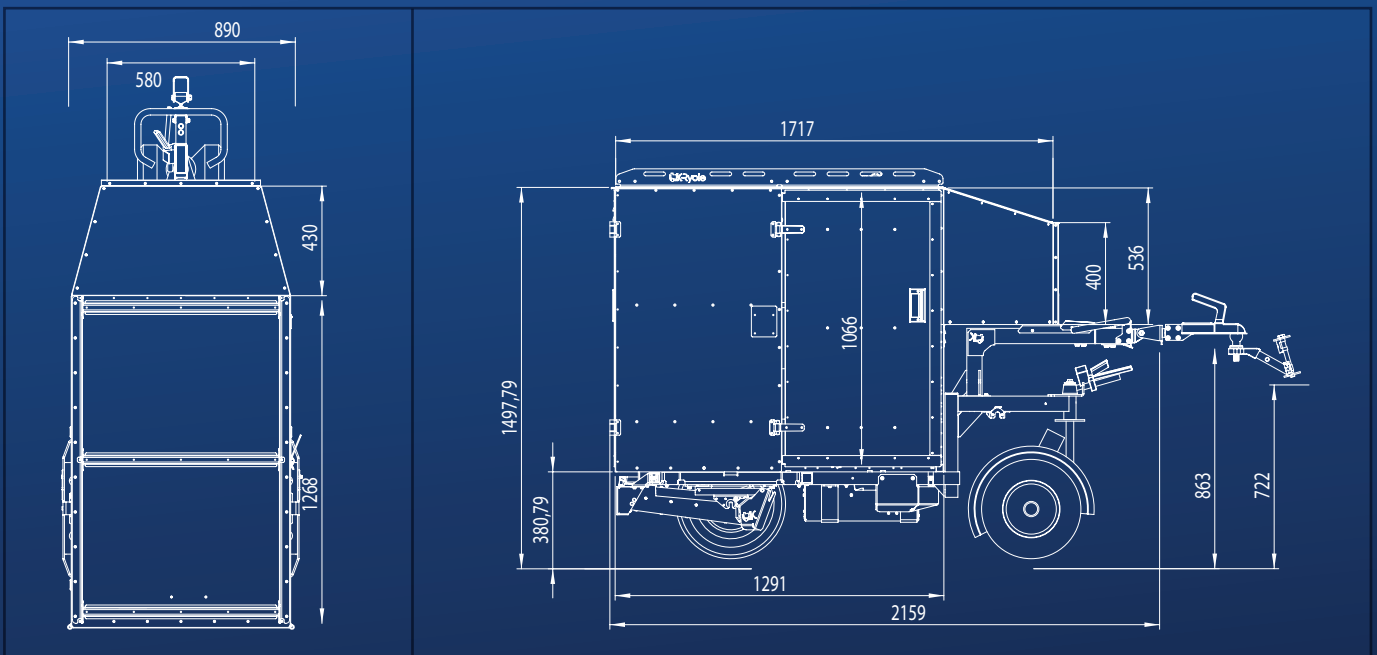

MAIN FEATURES		
Bodywork		Utility
Use		Hand / Bicycle
Warranty		2 years

TECHNICAL FEATURES			
Materials	6060 T6 tubular aluminium frame / Self-supporting tubular aluminium structure		
Electric motor	2 DC wheel motors		
Power	2 x 1500 W		
Empty vehicle weight	165 kg		
Length / Width / Height (drawbar folded)	2160 x 933 x 1531 mm		
Wheels	Front	Dimensions	8 inch rim
		Tyre	8"x3" Tubeless
	Rear	Type	Wheel hub motor rim
		Dimensions	10 inch
		Tyre	Reinforced tyre 100/90 tubeless (100/90 R10 61J TL RF
Technology	International patent	Kaptor K-Ryole : FR3048223BI	
	Force Cancellation Algorithm Calculation Period	Motors speed refresh rate 100 times per second	

PERFORMANCE		
Doors	Double rear door / Side door	
Roof rack	Max payload	Up to 20 kg
Maximum speed	Manual Mode	7 km/h
	Bicycle mode	25 km/h
Length / width / module height	Internal dimensions	1250x810x996
Max payload	Weight	Up to 350 kg
	Volumes	1.3 m3
	Standard crates (600 x 400 x 310 mm)	Up to 11 crates
Slope	4%	Payload 350 kg
	11%	Payload 180 kg
	15%	Payload 100 kg
Battery	Battery Type	NMC Lithium batteries (rackable)
	Capacity	1.6kWh
	Range / unit	+/- 30-40 km
	Charging time	4 h on 220 V mains
	Operating temperature	-10 – 45° C

SAFETY		
Brakes	Brake system	Electric braking
	Parking brake	Hydraulic brake
Braking distance (bike mode)	Payload 200 kg	15 km/h Dry pavement: 3.7 m / Wet pavement: 4.2 m
		25 km/h Dry pavement: 10 m / Wet pavement: 12 m
Suspension	Front	Shock absorber spring assembly (Stroke: 80 mm)
	Rear	Silent block
Anti-theft device	Parking mode	Motor lock (RFID system)
	Doors	Electronic locks (RFID system)
	Battery rack	Mechanical code locks
Cruise control / speed limiter	25 km/h	
Headlights	Position, brakes and reverse lights	
Bodywork strength	Sheet thickness	1 mm
	Impact protection	1 T tensile strength
On board Intelligence	Automatic speed limiter	Turns / descents
	Automatic safety system	Accidental uncoupling / Impacts
	Diagnosis and intelligent correction of anomalies	Hardware / Motors
	"Dead man" safety system (drawbar release detection)	Manual Mode

EQUIPMENT		
Trailer keypad interface	Hand and bike mode / Power on and off / Trailer calibration / Anti-theft mode / Maintenance indicators / Charge indicator	
Badge	Master badge (activation of user badges) / User badge (RFID function)	
Handle	Manual vehicle manoeuvring	
Bicycle hitch	Trailer	Caravan hitch on drawbar
	Bicycle	Tow ball with quick release seat post
Battery	Charging indicator	